

# FULL WELDED BALL VALVE SERIES





---

## FULL WELDED BALL VALVE

---

### STRUCTURAL FEATURES

---

#### 1、Integral Valve Structure

It is welded by forged steel. The forging materials are subjected to ultrasonic examination according to ASME nondestructive flaw detection requirements. The welding slope on the connection face is subjected to liquid penetration examination.

#### 13、Corrosion Resistance And Sulfide Stress Resistance

Certain corrosion allowance is left for the body wall thickness. The carbon steel stem, fixed shaft, ball, seat and seat ring are subjected to chemical nickel plating according to ASTM B733 and B656. In addition, various corrosion resistant materials are available for users to select.

According to customer requirements, the valve materials can be selected according to NACE MR 0175/ISO 15156 or NACE MR 0103, and strict quality control and quality inspection should be carried out during the manufacturing so as to fully meet the requirements in the standards and meet the service conditions in sulfurization environment.

### STRUCTURAL FEATURES

---

#### 15、Welding Of Transition Pipe

During the manufacturing of the fully welded pipeline ball valve, the transition pipe can be welded for the welding ends valve. The transition pipe can be supplied by users

or by our company according to user requirements. Please indicate the transition pipe diameter and length A when placing orders.

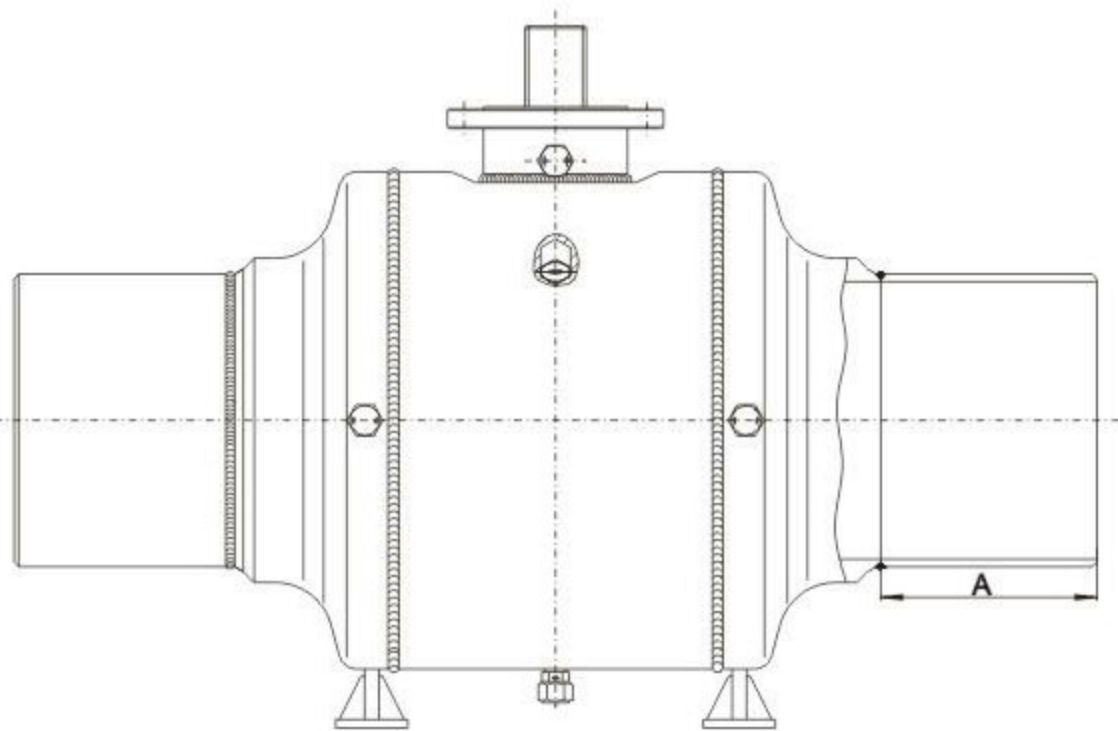

# FULL WELDED BALL VALVE

1	Body
2	Anti-fire packing
3	seat
4	Seat ring
5	O ring
6	Spring
7	Bonnet
8	Sealant injection valve
9	Check valve
10	Ball
11	Thrust gasket
12	Sliding bearing
13	Pin
14	Bearing holder
15	Seal gland
16	Thrust bearing
17	Stem
18	Flat key
19	Thrust bearing
20	Anti-fire gasket
21	Connection plate
22	Socket head cap screw
23	Packing
24	Packing gland
25	Anti-static device
26	Air release valve
27	Drainage valve

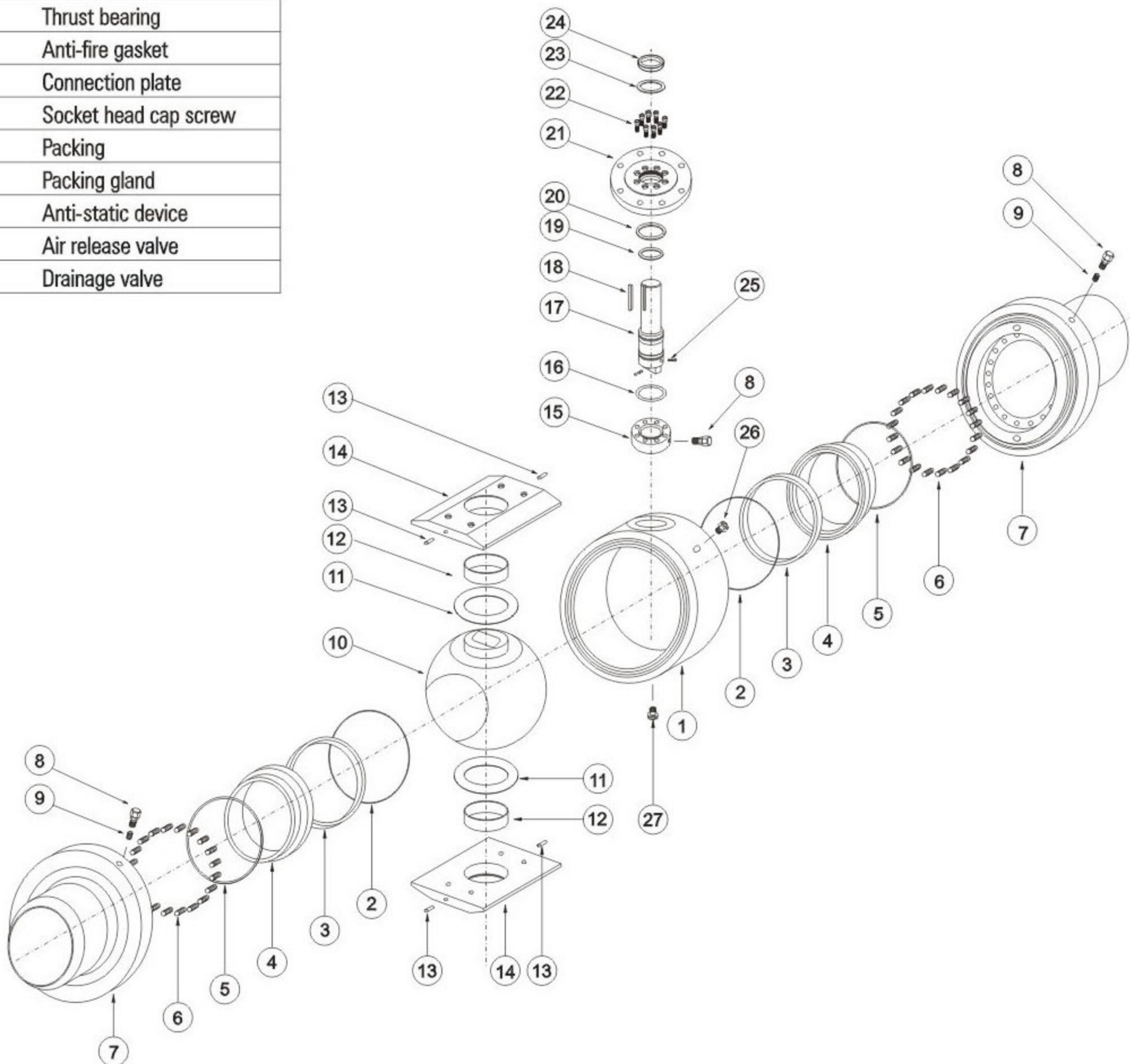



# FULL WELDED BALL VALVE

## Part Materials And Main Parameters

Nominal diameter (in)		NPS 6~40					
Nominal pressure (MPa)		Class150~Class1500					
Materials of parts	No.	Part Name	Materials				
			Carbon steel	Stainless steel			
	1	Body	ASTM A105	ASTM A182 304	ASTM A182 316	ASTM A182 304L	ASTM A182 316L
	2	Anti-fire packing	Graphite				
	3	seat	PTFE/NYOLN/PEEK/PPL				
	4	Seat ring	ASTM A105 • ENP	ASTM A182 304	ASTM A182 316	ASTM A182 304L	ASTM A182 316L
	5	O ring	VITON				
	6	Spring	17-7PH				
	7	Bonnet	ASTM A105	ASTM A182 304	ASTM A182 316	ASTM A182 304L	ASTM A182 316L
	8	Sealant injection valve	Combined parts	Combined parts	Combined parts	Combined parts	Combined parts
	9	Check valve	Combined parts	Combined parts	Combined parts	Combined parts	Combined parts
	10	Ball	ASTM A105 • ENP	ASTM A182 304	ASTM A182 316	ASTM A182 304L	ASTM A182 316L
	11	Thrust gasket	PTFE				
	12	Sliding bearing	Metal+PTFE	Metal+PTFE	Metal+PTFE	Metal+PTFE	Metal+PTFE
	13	Pin	ANSI 1035	ANSI 1035	ANSI 1035	ANSI 1035	ANSI 1035
	14	Bearing holder	ASTM A105 • ENP	ASTM A182 304	ASTM A182 316	ASTM A182 304L	ASTM A182 316L
	15	Seal gland	ASTM A105 • ENP	ASTM A182 304	ASTM A182 316	ASTM A182 304L	ASTM A182 316L
	16	Thrust bearing	PTFE				
	17	Stem	ASTM A182 F6a	ASTM A182 304	ASTM A182 316	ASTM A182 304L	ASTM A182 316L
	18	Flat key	ANSI 1045	ANSI 1045	ANSI 1045	ANSI 1045	ANSI 1045
	19	Thrust bearing	PTFE				
	20	Anti-fire gasket	SST+Graphite				
	21	Connection plate	ASTM A105	ASTM A182 304	ASTM A182316	ASTM A182 304L	ASTM A182 316L
	22	Socket head cap screw	A193 B7M	A320 B8	A320 B8M	A320 B8	A320 B8M
	23	Packing	Graphite	Graphite	Graphite	Graphite	Graphite
	24	Packing Gland	ASTM A182 F6a	ASTM A182 F6a	ASTM A182 F6a	ASTM A182 F6a	ASTM A182 F6a
	25	Anti-static Device	Combined parts	Combined parts	Combined parts	Combined parts	Combined parts
26	Air release valve	Combined parts	Combined parts	Combined parts	Combined parts	Combined parts	
27	Drainage valve	Combined parts	Combined parts	Combined parts	Combined parts	Combined parts	
Applicable service conditions	Applicable media	Water, steam,oil, gas, liquefied petroleum gas, natural gas	Nitric acid	Acetic acid	Strong Oxidizer	Urea	
	Applicable temperature	120°C (PTFE) 、 ≤80°C (NYLON) 、 ≤250°C (PEEK) 、 ≤250°C (PPL)					
Design and manufacturing		API 608、 API 6D					
Face-to-face dimensions		ASME B16.10、 API 6D、 JIS B2002					
Type of connection		Flange	ASME B16.5/ASME B16.47		Butt welding	ASME B16.25	
Pressure test		API 598、 API 6D					
Transmission mode		Manual, worm and worm gear transmission, pneumatic, electric					



# FULL WELDED BALL VALVE

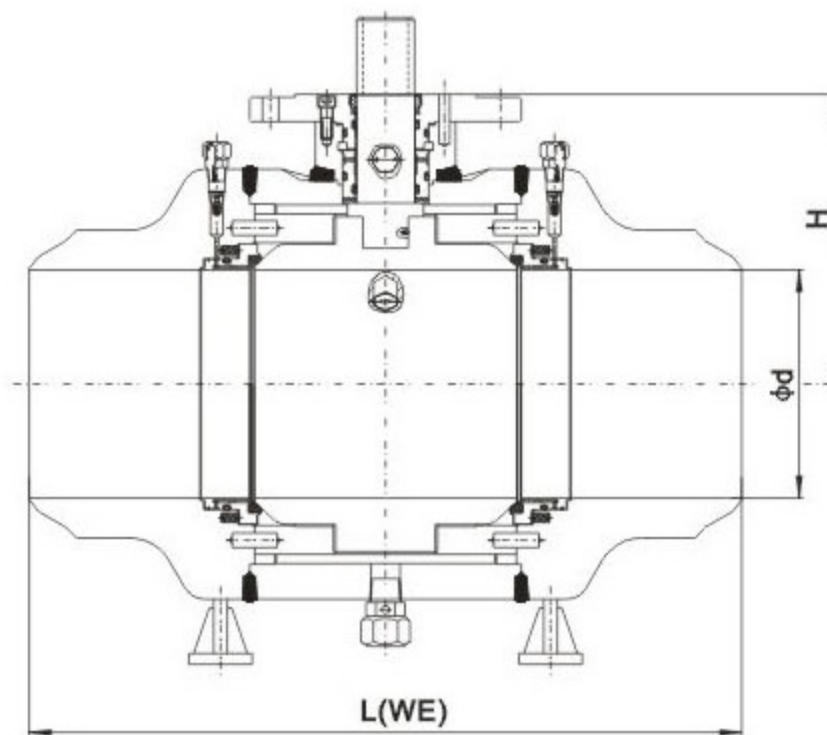
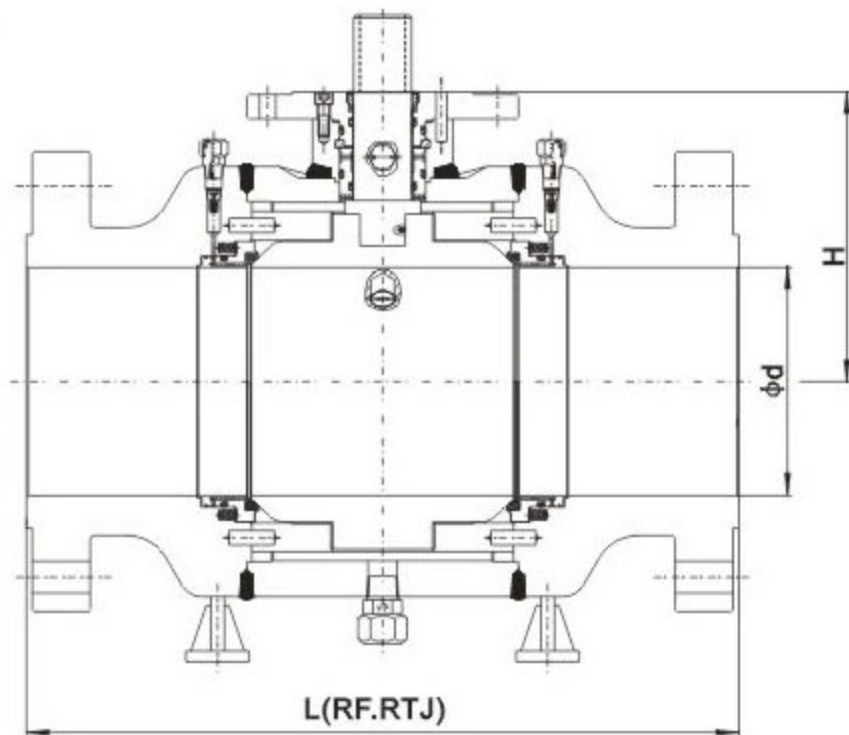

Pressure rating	Nominal Diameter		d	Flanged		Butt welding	H	Weight(kg)		
	Class	NPS		DN	L(RF)	L(RTJ)		L(BW)	WE	RF
150		6"	150	150	394	406	457	225	185	220
		8"	200	201	457	470	521	258	250	290
		10"	250	252	533	546	559	310	400	430
		12"	300	303	610	622	635	350	550	620
		14"	350	334	686	699	762	382	820	900
		16"	400	385	762	775	838	421	1100	1220
		18"	450	436	864	876	914	468	1400	1550
		20"	500	487	914	927	991	510	1750	1950
		24"	600	589	1067	1080	1143	592	2800	3050
		26"	650	633	1143	-	1245	635	2900	3250
		28"	700	684	1245	-	1346	675	3400	3700
		30"	750	735	1295	-	1397	723	4800	5300
		32"	800	779	1372	-	1524	751	5500	6000
		36"	900	874	1524	-	1727	858	7550	8370
	40"	1000	976	1753	-	1956	930	10290	11320	
300		6"	150	150	403	419	457	225	185	230
		8"	200	201	502	518	521	258	250	300
		10"	250	252	568	584	559	310	400	460
		12"	300	303	648	664	635	350	550	670
		14"	350	334	762	778	762	382	820	1000
		16"	400	385	838	854	838	421	1100	1320
		18"	450	436	914	930	914	468	1400	1650
		20"	500	487	991	1010	991	510	1750	2000
		24"	600	589	1143	1165	1143	592	2800	2550
		26"	650	633	1245	-	1245	635	2900	3300
		28"	700	684	1346	-	1346	675	3400	3750
		30"	750	735	1397	-	1397	723	4800	5500
		32"	800	779	1524	-	1524	751	5500	6500
		36"	900	874	1727	-	1727	858	7980	8800
	40"	1000	976	1956	-	1956	930	10290	11900	

Note: The weight value is only for flanged valve. Please consult our factory for higher nominal diameter or weight. Any modification to sizes H, and weight will not be notified otherwise.



# FULL WELDED BALL VALVE

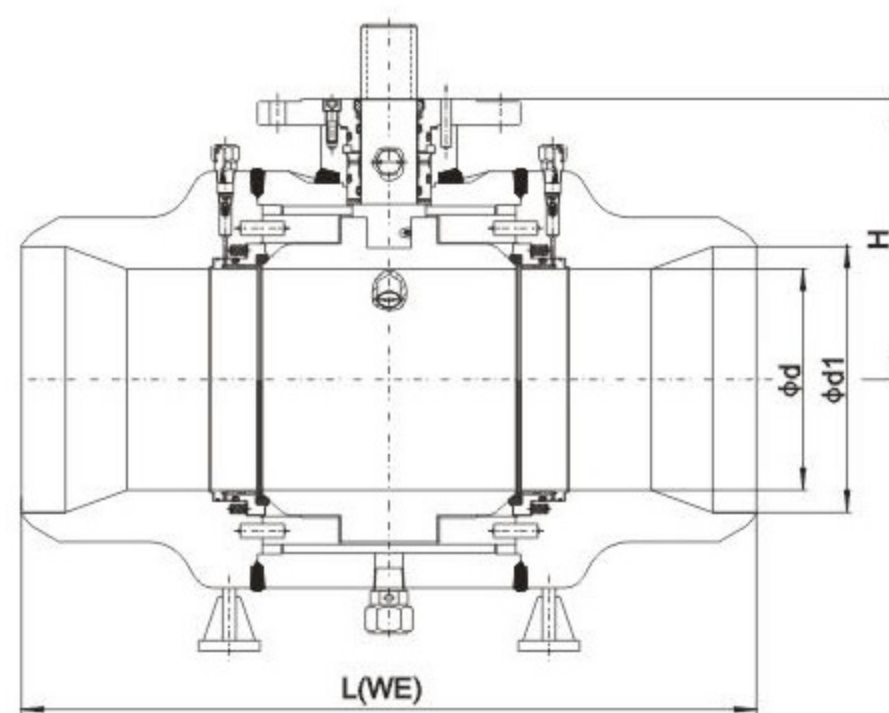
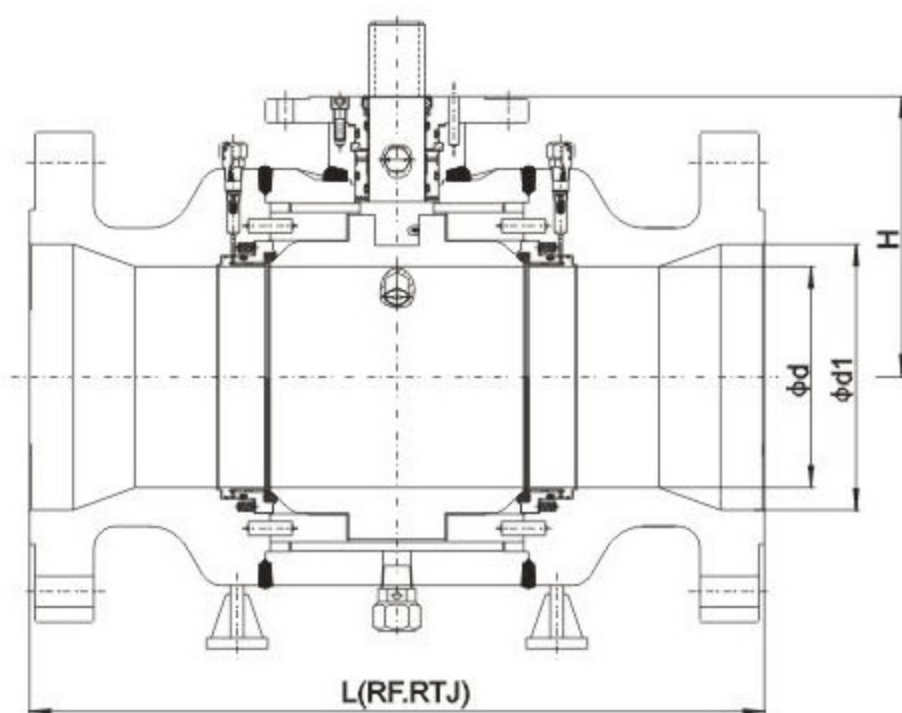

Pressure rating	Nominal Diameter		d	d1	Flanged		Butt welding	H	Weight(kg)		
	Class	NPS			DN	L(RF)	L(RTJ)		L(BW)	WE	RF
150		8" × 6"	200	150	201	457	470	521	225	△	△
		10" × 8"	250	201	252	533	546	559	258	△	△
		12" × 10"	300	252	303	610	622	635	310	△	△
		14" × 10"	350	252	334	686	699	762	310	△	△
		14" × 12"	350	303	334	686	699	762	350	△	△
		16" × 12"	400	303	385	762	775	838	350	△	△
		16" × 14"	400	334	385	762	775	838	382	△	△
		18" × 16"	450	385	436	864	876	914	421	△	△
		20" × 16"	500	385	487	914	927	991	421	△	△
		20" × 18"	500	436	487	914	927	991	468	△	△
		24" × 20"	600	487	589	1067	1080	1143	510	△	△
		30" × 24"	750	589	735	1295	-	1397	592	△	△
	36" × 30"	900	735	874	1524	-	1727	723	△	△	
300		8" × 8"	200	150	201	502	518	521	225	△	△
		10" × 8"	250	201	252	568	584	559	258	△	△
		12" × 10"	300	252	303	648	664	635	310	△	△
		14" × 10"	350	252	334	762	778	762	310	△	△
		14" × 12"	350	303	334	762	778	762	350	△	△
		16" × 12"	400	303	385	838	854	838	350	△	△
		16" × 14"	400	334	385	838	854	838	382	△	△
		18" × 16"	450	385	436	914	930	914	421	△	△
		20" × 16"	500	385	487	991	1010	991	421	△	△
		20" × 18"	500	436	487	991	1010	991	468	△	△
		24" × 20"	600	487	589	1143	1165	1143	510	△	△
		30" × 24"	750	589	735	1397	1422	1397	592	△	△
	36" × 30"	900	735	874	1727	1756	1727	723	△	△	

△ Please consult the factory:

Note: The weight value is only for flanged valve. Please consult our factory for higher nominal diameter or weight. Any modification to sizes Hand weight will not be notified otherwise.



# FULL WELDED BALL VALVE

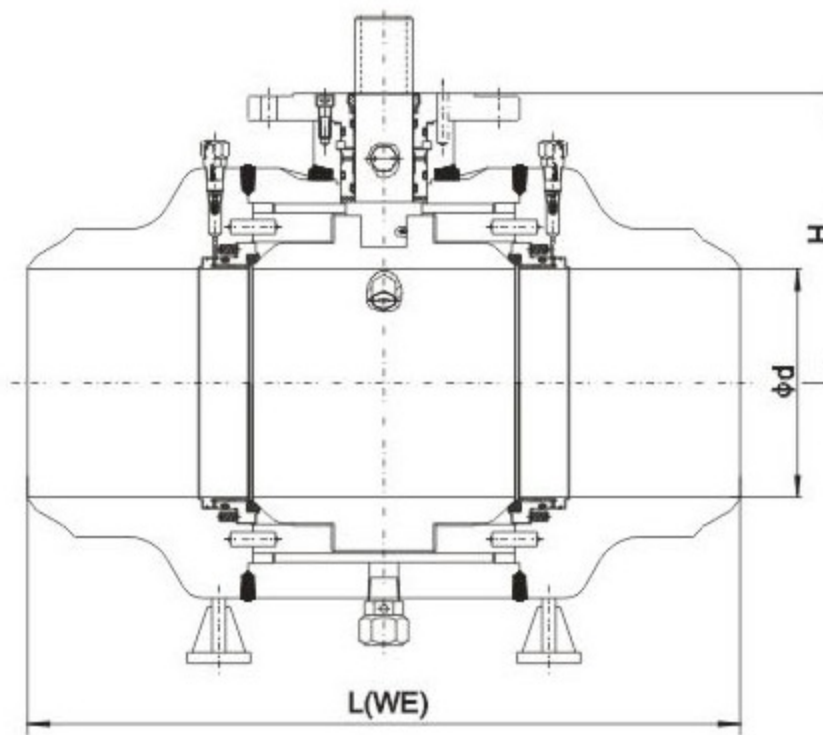
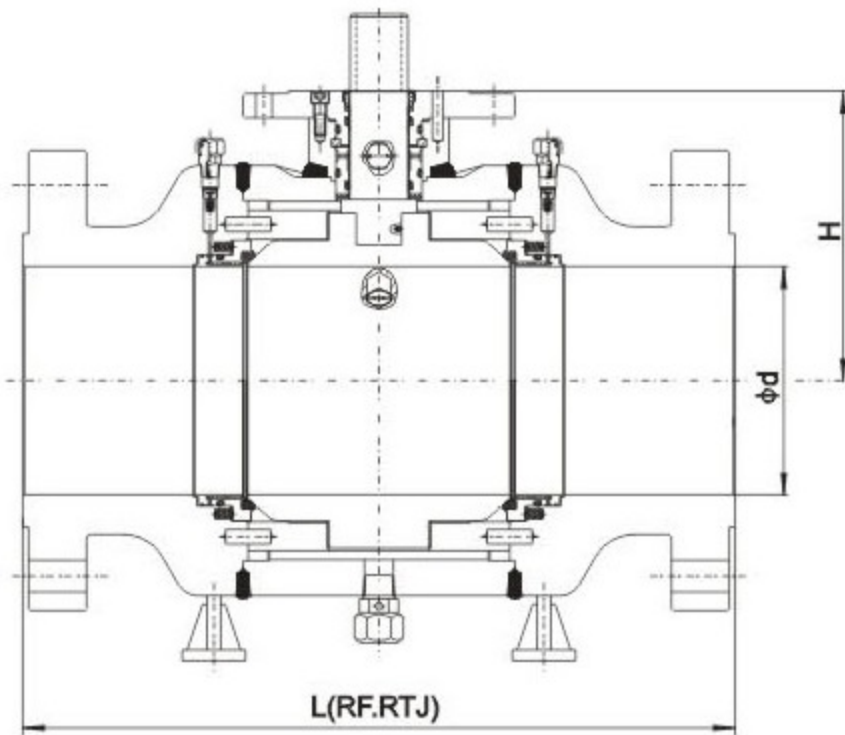

Pressure rating	Nominal Diameter		d	Flanged		Butt welding	H	Weight(kg)		
	Class	NPS		DN	L(RF)	L(RTJ)		L(BW)	WE	RF
600		6"	150	150	559	562	559	255	250	330
		8"	200	201	660	664	660	290	340	450
		10"	250	252	787	791	787	320	570	710
		12"	300	303	838	841	838	380	850	1000
		14"	350	334	889	892	889	410	1100	1370
		16"	400	385	991	994	991	435	1350	1650
		18"	450	436	1092	1095	1092	495	2100	2400
		20"	500	487	1194	1200	1194	535	2600	3000
		24"	600	589	1397	1407	1397	642	3700	4300
		26"	650	633	1448	-	1448	665	3900	4500
		28"	700	684	1549	-	1549	704	4200	4900
		30"	750	735	1651	-	1651	745	6000	6900
		32"	800	779	1778	-	1778	785	6800	8000
	36"	900	874	2083	-	2083	875	9570	10850	
900		6"	150	150	610	613	610	255	330	430
		8"	200	201	737	740	737	290	400	520
		10"	250	252	838	841	838	320	640	820
		12"	300	303	965	968	965	380	900	1050
		14"	350	322	1029	1038	1029	410	1020	1400
		16"	400	373	1130	1140	1130	435	1350	2050
		18"	450	423	1219	1232	1219	495	2600	3400
		20"	500	471	1321	1334	1321	535	3700	4200
		24"	600	570	1549	1568	1549	642	4400	5400
1500		6"	150	144	705	711	705	255	375	565
		8"	200	192	832	841	832	290	415	505
		10"	250	239	991	1000	991	320	525	640
		12"	300	287	1130	1146	1130	380	780	950
		14"	350	315	1257	1276	1257	410	1145	1380

Note: The weight value is only for flanged valve. Please consult our factory for higher nominal diameter or weight. Any modification to sizes H, and weight will not be notified otherwise.



# FULL WELDED BALL VALVE

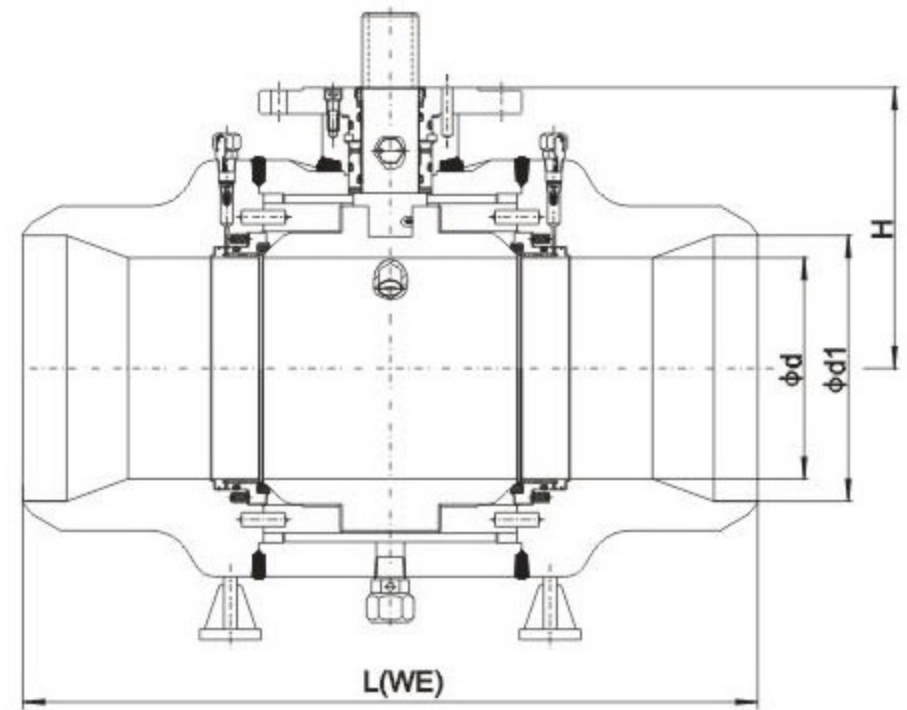
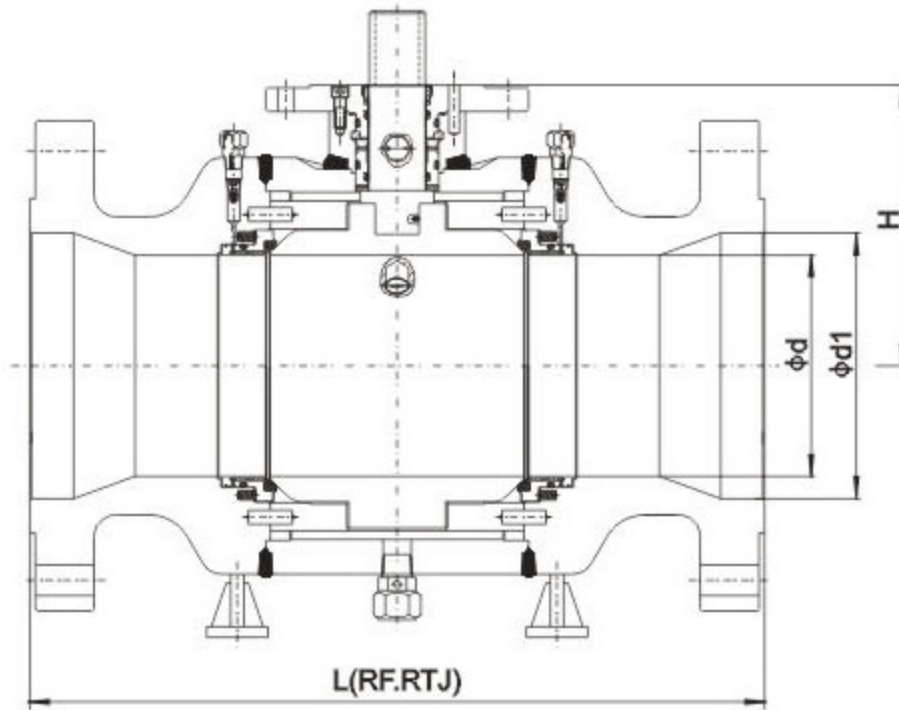

Pressure rating	Nominal Diameter		d	d1	Flanged		Butt welding	H	Weight(kg)		
	Class	NPS			DN	L(RF)	L(RTJ)		L(BW)	WE	RF
600		8" × 6"	200	150	201	660	664	660	255	△	△
		10" × 8"	250	201	252	787	791	787	290	△	△
		12" × 10"	300	252	303	838	841	838	320	△	△
		14" × 10"	350	252	334	889	892	889	380	△	△
		14" × 12"	350	303	334	889	892	889	380	△	△
		16" × 12"	400	303	385	991	994	991	380	△	△
		16" × 14"	400	334	385	991	994	991	410	△	△
		18" × 16"	450	385	436	1092	1095	1092	435	△	△
		20" × 16"	500	385	487	1194	1200	1194	435	△	△
		20" × 18"	500	436	487	1194	1200	1194	495	△	△
		24" × 20"	600	487	589	1397	1407	1397	535	△	△
		30" × 24"	750	589	735	1651	-	1651	642	△	△
		36" × 30"	900	735	874	2083	-	2083	745	△	△
900		8" × 6"	200	150	201	737	740	737	255	△	△
		10" × 8"	250	201	252	838	841	838	290	△	△
		12" × 10"	300	252	303	965	968	965	320	△	△
		14" × 10"	350	252	322	1029	1038	1029	320	△	△
		14" × 12"	350	303	322	1029	1038	1029	380	△	△
		16" × 12"	400	303	373	1130	1140	1130	380	△	△
		16" × 14"	400	322	373	1130	1140	1130	410	△	△
		18" × 16"	450	373	423	1219	1232	1219	435	△	△
		20" × 16"	500	373	471	1321	1334	1321	435	△	△
		20" × 18"	500	423	471	1321	1334	1321	495	△	△
		24" × 20"	600	471	570	1549	1568	1549	535	△	△
1500		8" × 6"	200	144	192	832	841	832	255	△	△
		10" × 8"	250	192	239	991	1000	991	290	△	△
		12" × 10"	300	239	287	1130	1146	1130	320	△	△
		14" × 10"	350	239	315	1257	1276	1257	320	△	△
		14" × 12"	350	287	315	1257	1276	1257	380	△	△
		16" × 12"	400	287	360	1384	1407	1384	380	△	△

△ Please consult the factory:

Note: The weight value is only for flanged valve. Please consult our factory for higher nominal diameter or weight. Any modification to sizes Hand weight will not be notified otherwise.